

# 1556 POWER CARTRIDGE ASSEMBLIES

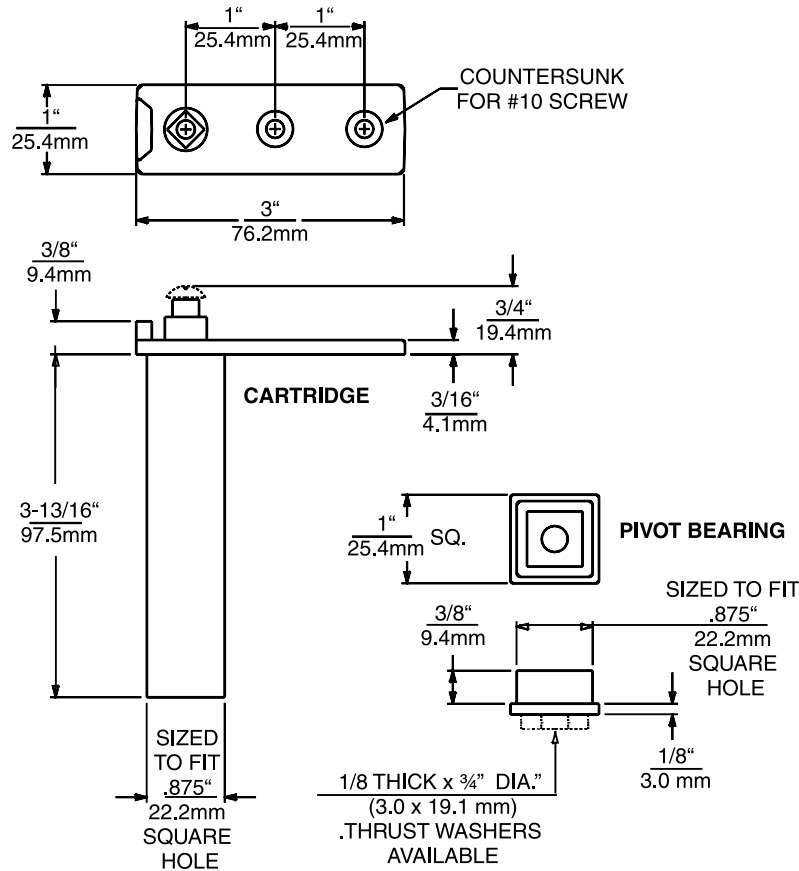

Model No.	Item	Quantity/ Carton	Weight./Carton
1556000004	Spring Cartridge Assembly, Standard Clearance, 120° stop.	48	24 lb. (10.9kg)
1556000008	Spring Cartridge Assembly, Minimal Clearance, no stop.	48	24 lb. (10.9kg)
1556000011	Top Left Hand Cartridge Bracket	24	8 lb. (3.6kg)
1556000012	Top Right Hand Cartridge Bracket	24	8 lb. (3.6kg)
1556000013	Bottom Left Hand Cartridge Bracket	24	8 lb. (3.6kg)
1556000014	Bottom Right Hand Cartridge Bracket	24	8 lb. (3.6kg)
1556000021	Top Left Hand Pivot Bracket	24	8 lb. (3.6kg)
1556000022	Top Right Hand Pivot Bracket	24	8 lb. (3.6kg)
1556000023	Bottom Left Hand Pivot Bracket	24	8 lb. (3.6kg)
1556000024	Bottom Right Hand Pivot Bracket	24	8 lb. (3.6kg)
1556000035	Double Left Hand Pivot Bracket	24	8 lb. (3.6kg)
1556000036	Double Right Hand Pivot Bracket	24	8 lb. (3.6kg)
1556000257	Thrust Washer, 1/8" ( 3.2mm) for 1556 Hinge	100	1 lb. (0.45kg)

BRACKETS SHOWN ON FOLLOWING PAGE

## 1556 BRACKETS

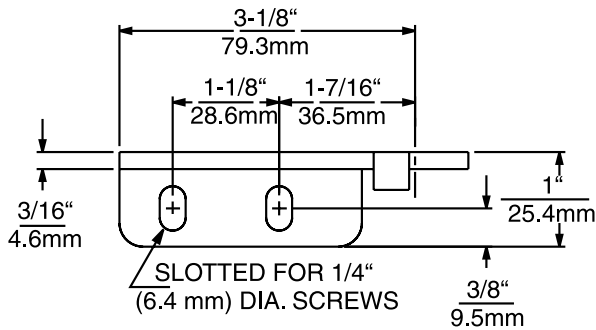
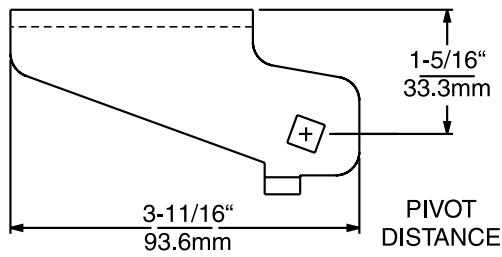

### 1556-12

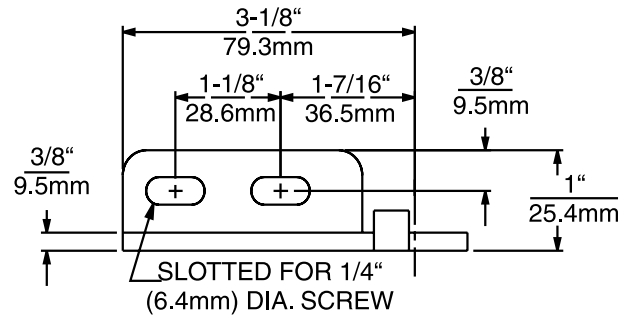
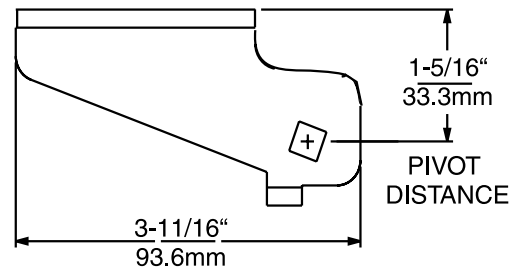

### 1556-14

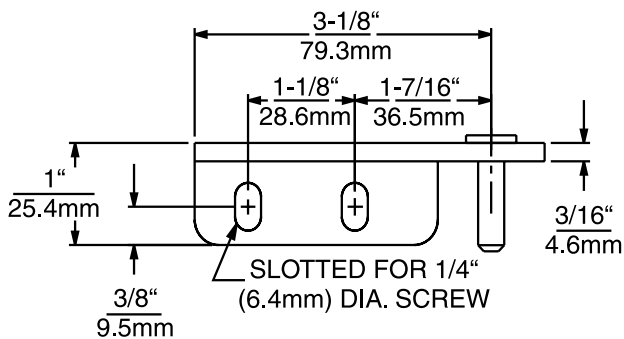
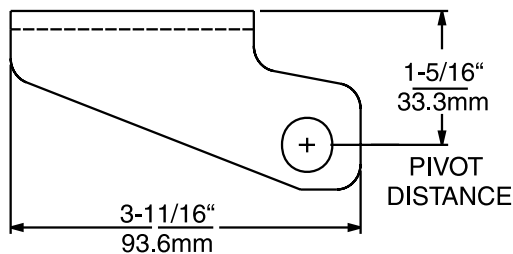

### 1556-22

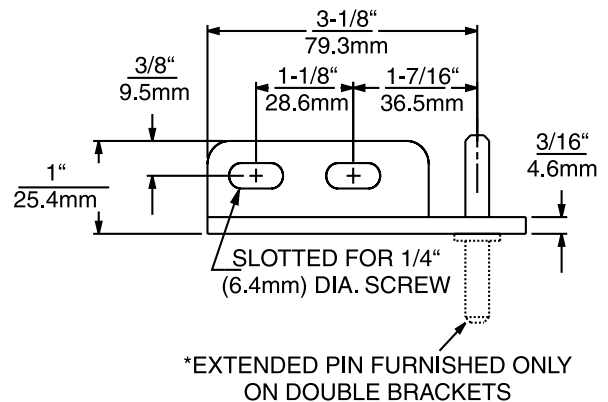
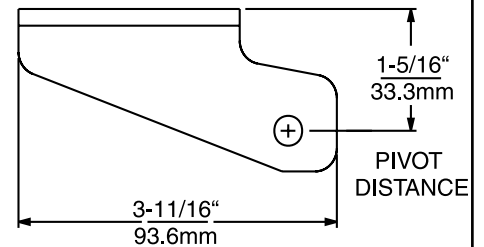

### 1556-24 WITHOUT EXTENDED PIN

### 1556-36 WITH EXTENDED PIN